

The Experiment of kHz Laser Ranging with Nanosecond Pulses at Shanghai SLR

Zhang Zhongping, Yang Fumin, Wu Zhibo, Zhang Haifeng, Chen Juping, Qin Si, Li Pu
Shanghai Observatory, Chinese Academy of Sciences, Shanghai, China
zzp@shao.ac.cn /Fax:+86-21-64696290

Abstract

The paper presents some progress on kHz ranging at Shanghai SLR station:

- 1) design and build a range gate generator with 5ns resolution based on a FPGA chip for kHz ranging;*
 - 2) measure time of laser flight with a Riga A032-Event Timer;*
 - 3) complete kHz control system made up of two computers: One is for registering start and stop events and matching them, displaying O-C, identifying returns, storing results; another is for tracking and controlling, range gating;*
 - 4) establish pre-processing software for handling kHz data on Windows Operating System.*
- In April 2008, we borrowed a diode-pumping Q-switched Nd: YAG laser with 50ns pulse width, 2 mJ in 532nm and 1kHz repetition from North China Research Institute of Electro-Optics (NCRIEO) in China. This paper gives the preliminary results of 1KHz satellite ranging with the ns-pulses laser.*

Introduction

We have got the support from national natural science foundation and Chinese Academy of Sciences to research on kHz SLR and borrowed a kHz laser with long pulse width from NCRIEO. The experiment has been designed with the purpose of testing our design of kHz control system: range gate generator board, event timer, control software and data acquisition, data processing capability. On Apr.26 2008, we successfully got returns from Ajisai satellite for the first time with kHz system. Within the following week, the experiment has been done at ERS-2, Lageos etc. with 2mJ energy, 50ns pulse width laser.

KHz Laser

The main specifications of kHz laser made by NCRIEO are listed in Table 1.

Table 1. Main specifications of the kHz laser

Repetition rate	Up to 10kHz
Pulse width	50ns
Energy per pulse	2mJ @ 532nm
Divergence	6mrad
Size	52*17*12cm

The optical structure of the kHz laser system is shown in Figure1 and Figure 2

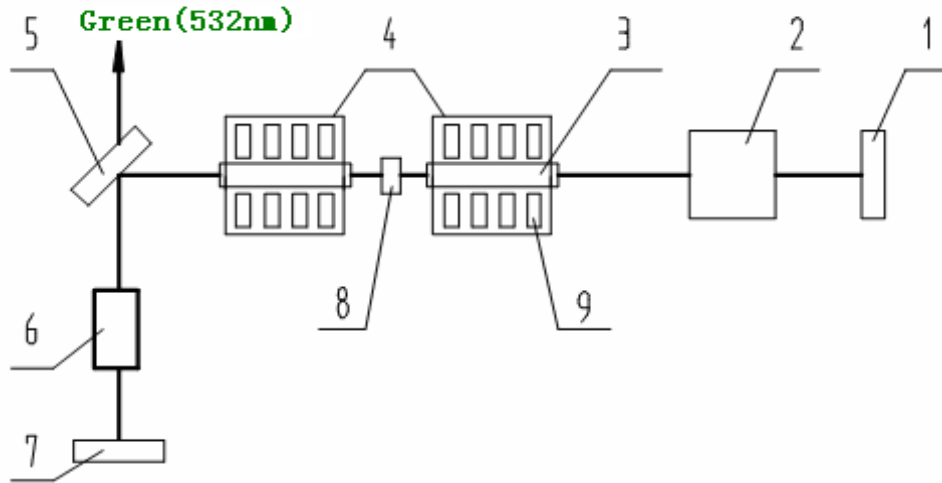

1, 7 HR concave mirror; 2. acousto-optic device; 3 .Nd:YAG rod;
 4. focus lamp cavity; 5. output coupling mirror; 6. SHG; 8. polarimeter;
 9. diode array

Figure 1. The optical structure of the kHz laser system

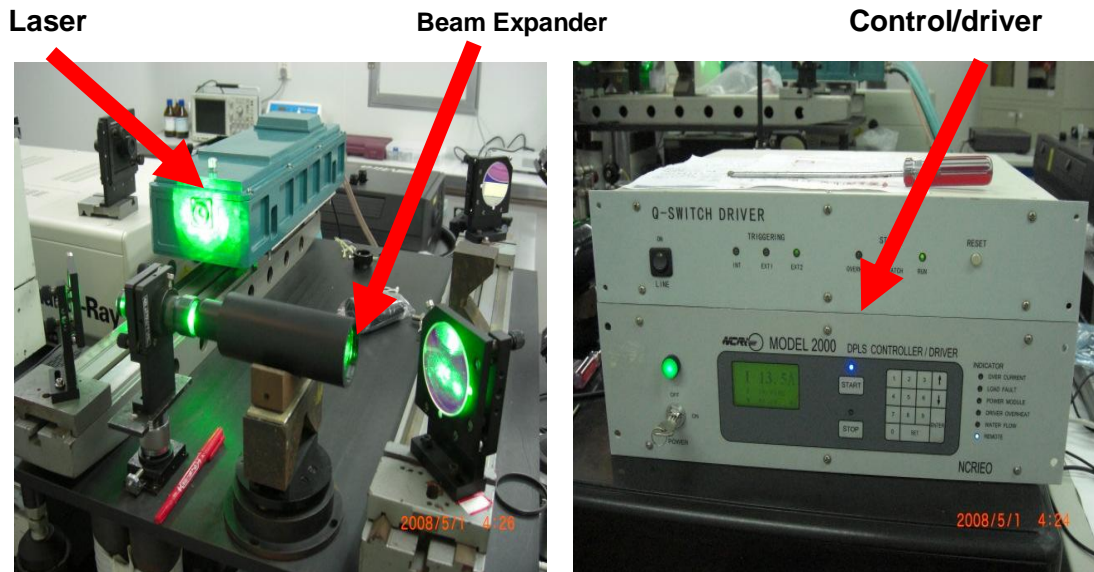

Figure 2. The kHz laser in operation

Event Timer (ET)

We develop the A032-ET functions to adapt for kHz ranging and develop our own data acquisition software with Visual C++, according to the library functions which defines device-specific function. Table 2 lists the specification of A032-ET. Figure3 and Figure 4 show how to use A032-ET.

Table 2. The specification of A032-ET

Single shot RMS	<10ps
Measurement rate	up to 10kHz
FIFO	12000 time-tags
Communication port	EPP



Made by Riga, Latvia

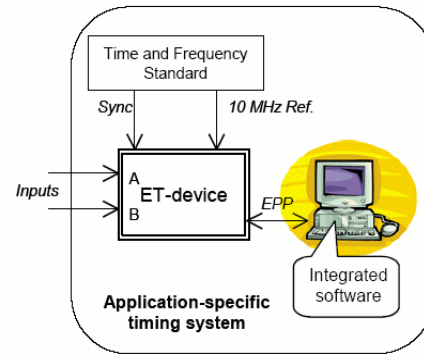

A032-Event Timer EPP mode

Figure 3. The timing system for SLR based on A032-ET

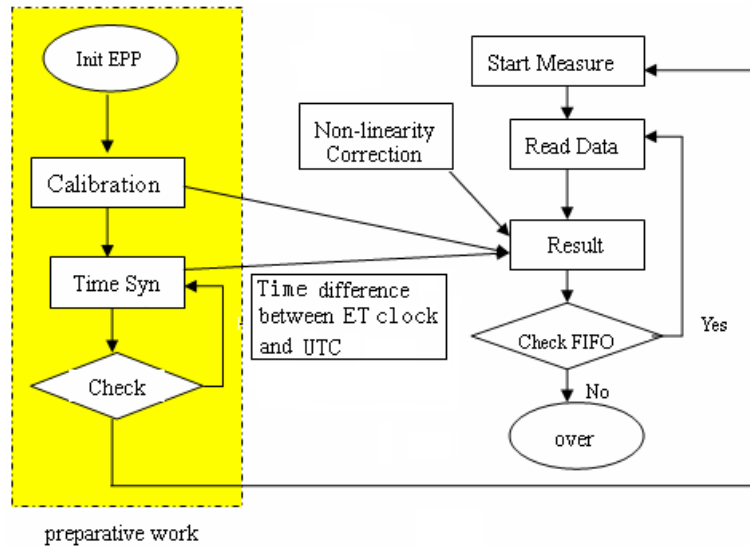

Figure 4. The schematic control diagram for A032-ET

kHz Range Gate Generators (RGG)

We have two RGGs: one from Graz with parameter of 0.5ns resolution, 1ns accuracy, 512 buffers and ISA mode, another developed by our group with 5ns resolution, 1024 buffers and EPP mode.

At the beginning phase of the experiment, Graz board is used. After that, we use our own RGG board to measure several satellites. Figure5 shows the layout of our RGG. The Real Time clock module synchronizes to UTC with 5ns resolution.

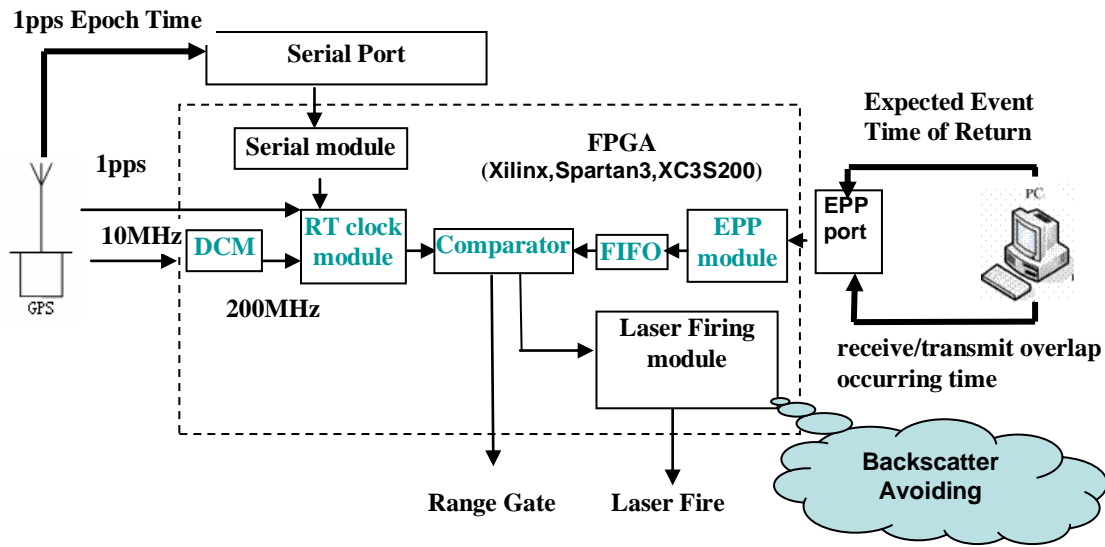

Figure 5. Layout of Shanghai’s Range Gate Generator

If expected event time of return equals to real time, then range gate is generated. If receive/transmit overlap occurring time equals to real time, then backscatter avoiding function of laser firing module will start. The timing sequences of backscatter avoiding are shown in Figure6. If the delay between expected epoch time of return and laser firing is less than defined time interval, e.g.100us, then backscatter avoiding module will shift the following laser firings by another defined time interval backward, e.g.120us.

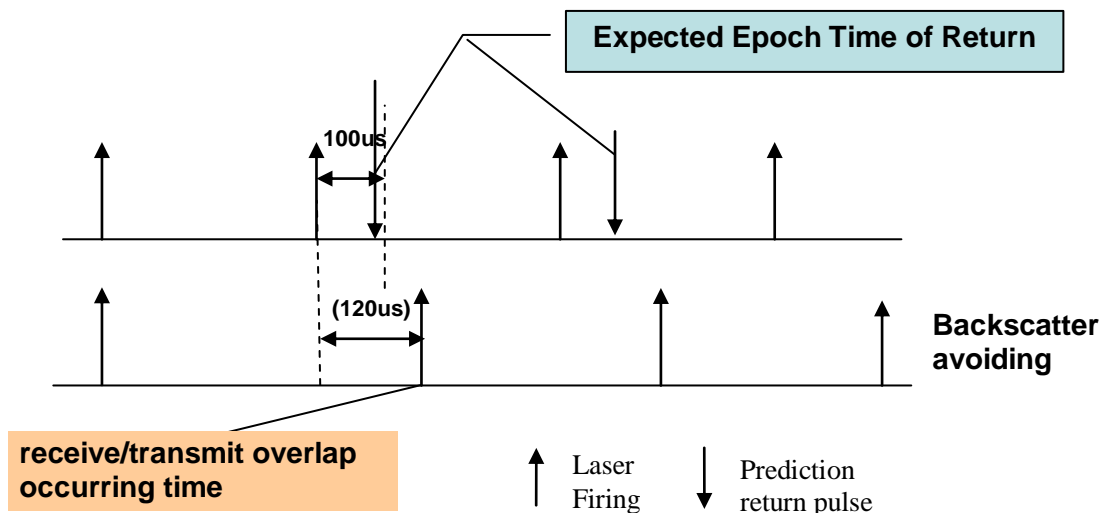

Figure 6. Timing sequences of backscatter avoiding

KHz Control Software System

Due to high real-time in kHz SLR controlling, we adopt two computers in the experiment in Windows OS: One computer is used for communicating with ET, recording start and stop events, and matching them, identifying, displaying range residual (O-C), storing data, etc. The software interface is shown in Figure8; Another computer is used for track and control which includes laser firing, range gating, receive/transmit overlap avoiding, etc. The software interface for this computer is shown in Figure9. During the experiment, the two computers communicate with each other via RS232. Block diagram of kHz system is shown in Figure 7.

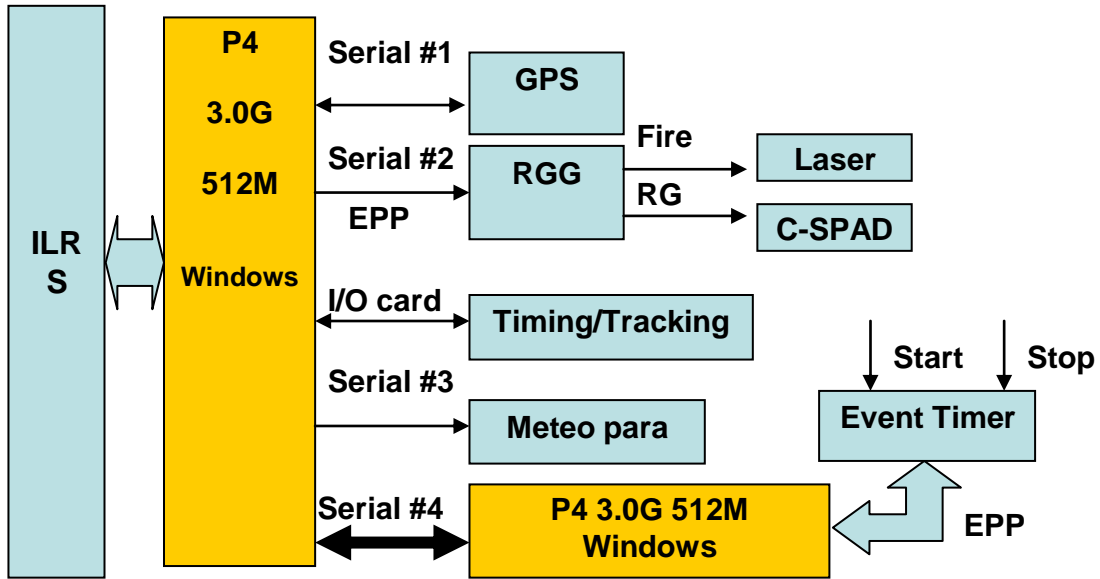

Figure 7. Block diagram of kHz system

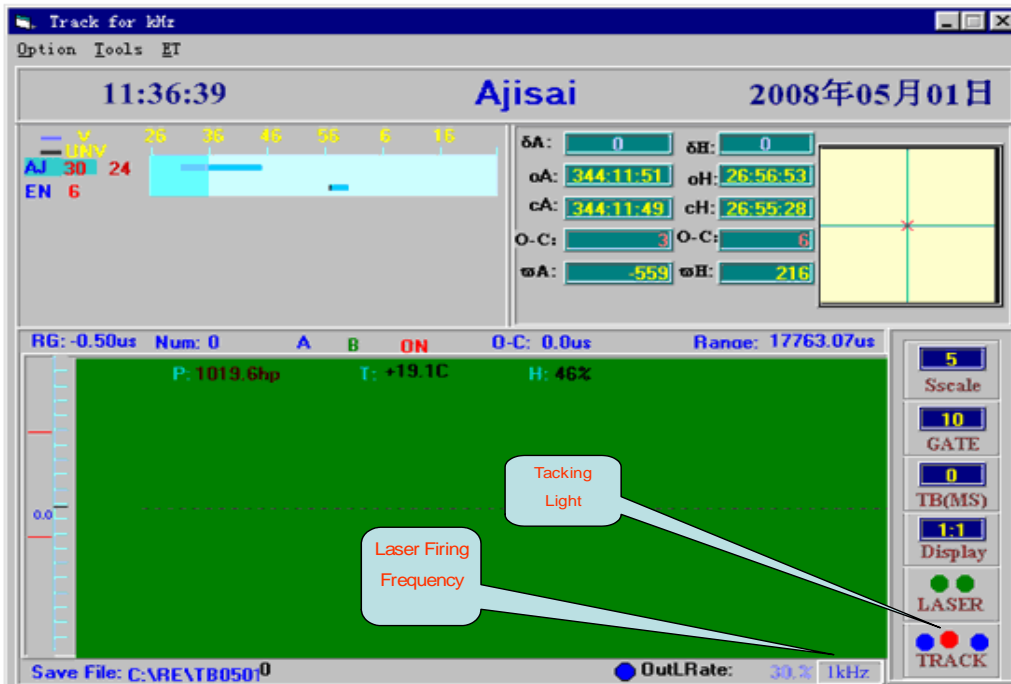

Figure 8. Real-time tracking interface for tracking, firing...

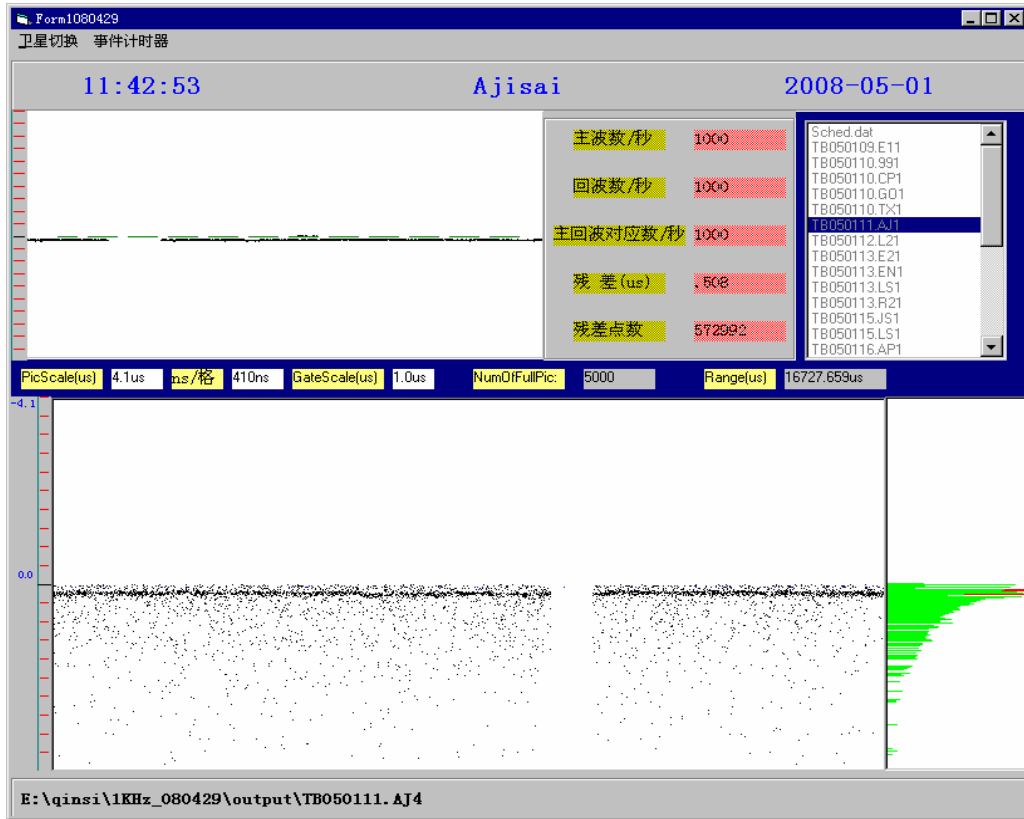

Figure 9. Another computer's real-time interface

Although kHz SLR control is highly real-time, we put expected epoch time of return into RGG in advance to ensure that kHz control software will run well in windows OS. Time sequencing diagram of writing RGG is shown as Figure10.

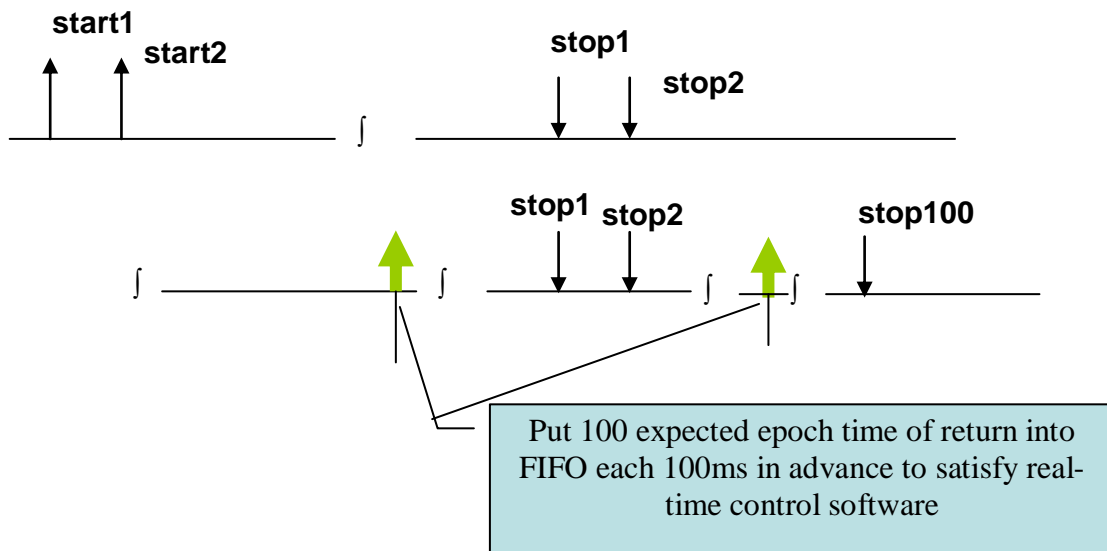

Figure 10. Time sequencing diagram of writing RGG

Data Pre-Processing

Because it takes a lot of time to display all observation data measured with 1kHz, we have developed a new data pre-processing program to process all data and only a part of them are displayed. This method increases the displaying speed without affecting the result. Comparison between the two ways of data displaying is shown in Figure 11.

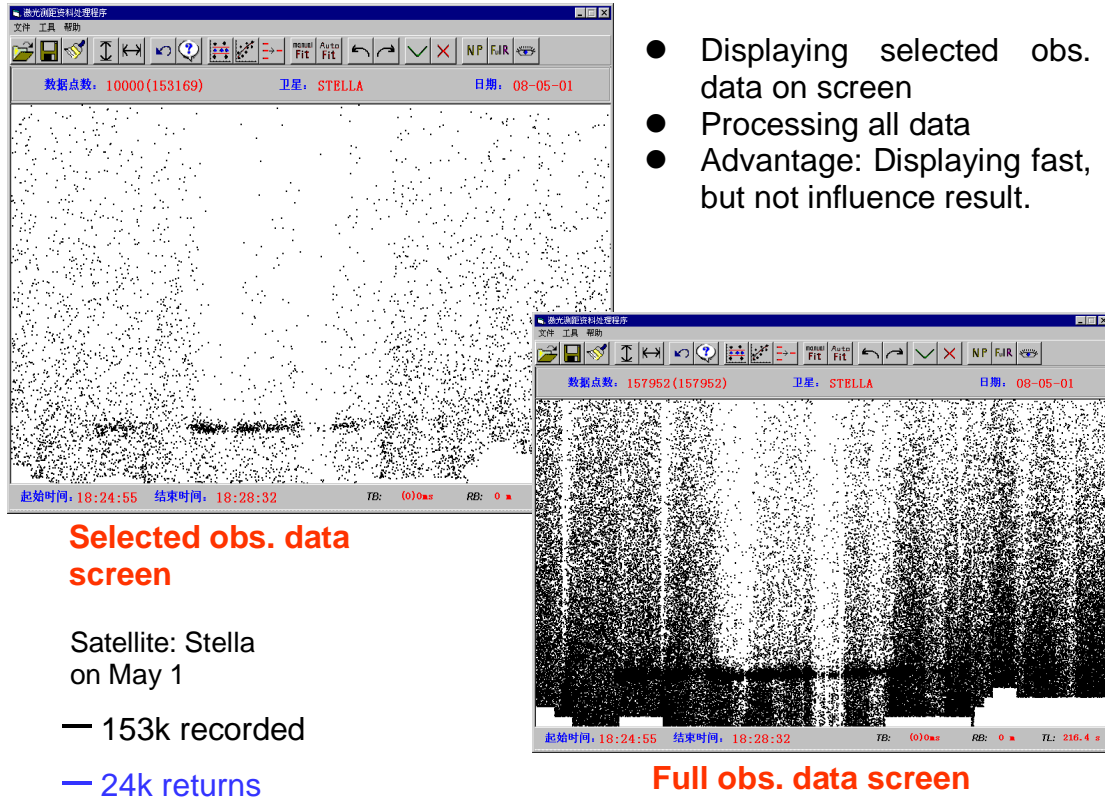

Figure 11. Method of Data Pre-Processing

Experiment Results

Since Apr.26 2008, we have successfully got returns from LEO satellites (Ajisai, Stella, BeaconC, ERS-2, Envisat, etc.) and Lageos with our kHz system, real-time interface for Lageos ranging is shown in Figure 12. Table 3 lists our kHz experiment results.

Table 3. kHz SLR returns vs. Routine SLR at Shanghai station

Satellite	KHz SLR		Routine SLR
	Recorded	Returns	Returns
Ajisai	618k	190k	1500
Stella	153k	24k	500
BeaconC	81k	42k	800
Lageos1	900k	60k	1000

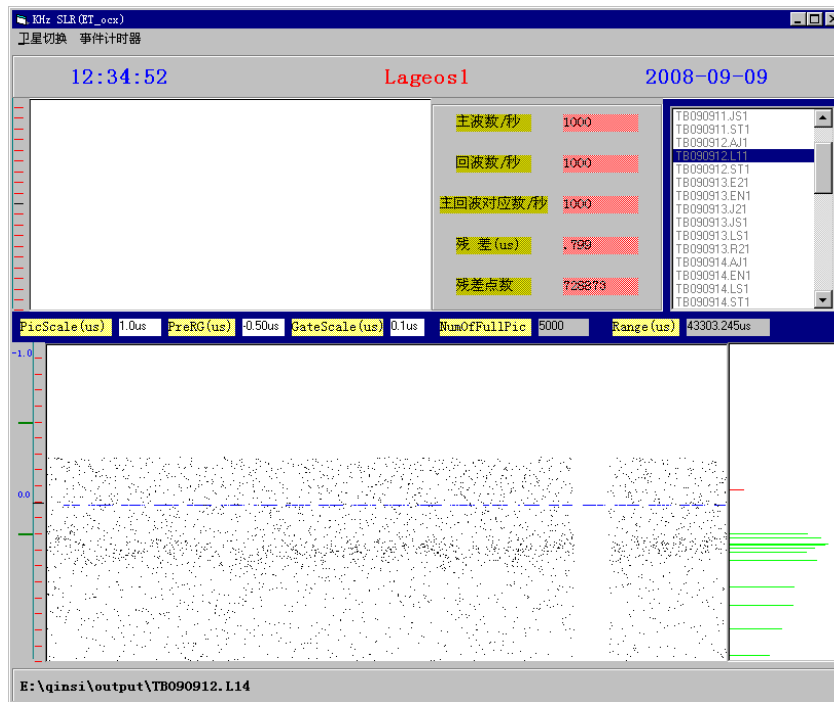

Satellite:
Lageos-1
on Sep. 9
— 900k
recorded
— 60k
returns

Figure 12. Real-time interface for Lageos ranging

Summary and future plans

We have successfully obtained returns from satellites (Ajisai, Stella, BeaconC, ERS-2, Envisat, Lageos, etc.) by using a kHz laser with long pulse width. The experiment shows that our kHz control system works fine and promise fully. Now fund has been gotten from China government to purchase a kHz laser with short pulse width next year, and then high-precision routine kHz ranging will be started.

References

- [1] V. Bepal'ko, E. Boole, V. Vedin, *THE MODEL A032-ET OF RIGA EVENT TIMERS*, 15th International Workshop on Laser Ranging, Canberra, Australia, 15-20 October, 2006
- [2] G. Kirchner, F.Koidl, *Graz KHz SLR System: Design, Experiences and Results*, 14th International Workshop on Laser Ranging, San Fernando, Spain, 7-11 June, 2004
- [3] G. Kirchner, *SLR Graz: The RGG (Range Gate Generator)*, ILRS kHz Technical Meeting, Graz, Austria, October 27-29, 2004
- [4] G. Kirchner, *Real Time Return Detection*, ILRS kHz Technical Meeting, Graz, Austria, October 27-29, 2004